

Secondary Structure: Group II intron

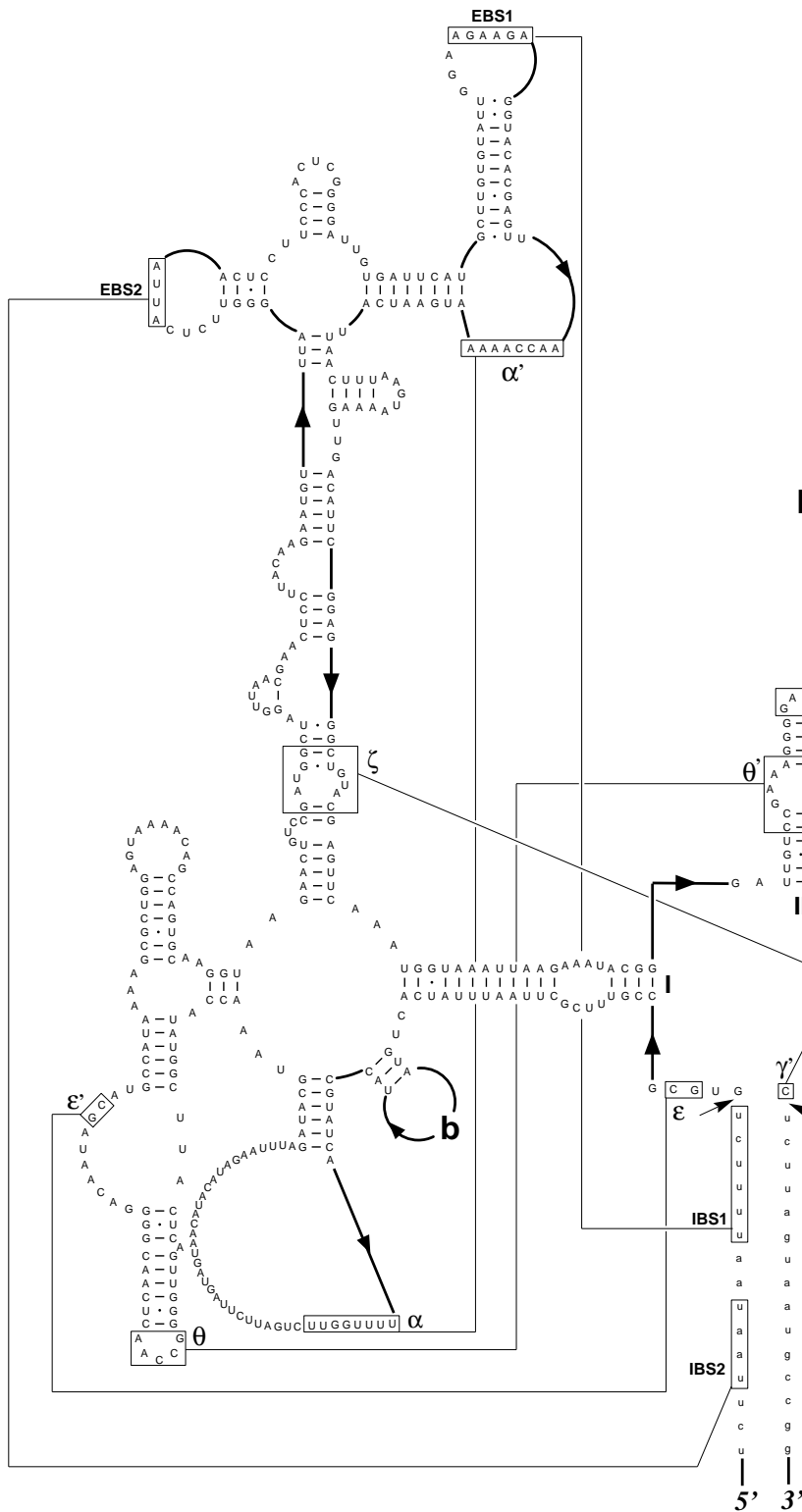

a 5'- AAAGAUAUAUCGCGGAUUUUUCUGAGUUAAUUAUUUAUGAAAUA
 AUUUGAUUAUCCAAAACCAUUAUUUAUUAUUAUUUAUUUAUUUAUGUCA
 GAUUAUUAAGAUUUUUUUUUUUUUUAUUUUUUUUUUUUUUUUUUUUUUUUUU
 UAAUUUAUUCUAAAAGGUUCUAAAUAUUUAUUUACCUUUGAUGGAUUUAUUUU
 CAUUUUUUUUUUUUUUUUUAUGUAAAACAUUUUAUACUAAUUUGUUUUUUUUUU
 UCUCUGUUUUAAGAGUUUAUUUCCUAAAACAUUCUGGAGGUUUUAGACC
 UUUUAAGUGUUGGUUAUCCUAGAAGAAAUUUUUUAACAAAAGUUAGAA
 UAAUUUUUAAGAAUUUUUUUAACAUAUGUUUUUUUUUUUUUUUUUUUUUUUUUU
 UUUUGACCAACUUUUCUUUUUAACAGCUUUUUUUUUUUUUUUUUUUUUUUUUUU
 UAUUUAACACUGUAUUUGAUUUUUUAAGUAUUUUUUUUUUUUUUUUUUUUUUUU
 AUACAUUUCCACAUAUUUGUUUUUUUUUUUUUUUUUUUUUUUUUUUUUUUUUUUU
 GAUUAAGGUUUUAUU
 UGAUUAACAUAUUUUUUUAUCAUCAACAACUUUAGGAAUUCUUAAGGUA
 GUGUUGUCAGUCCUU
 UAUUUUAGAAAUAUUUUUUUAGAAUUAUCAUUUCAUUACUGGAUCUAUGUCUAA
 UAGAAGUAUUAUCCAAUUUUUUUAUUAUUUUUUUAUACUUAUUUUUUUUUUUUUU
 GUAAAUU
 CAAAGAAAUU
 AUUAGCUGAUUU
 AAAUU
 UCUUU
 UUU
 GAAUGAUUU
 UUAUU
 UGGUU
 UAAUUUAUUAAGAAUU
 AGGGUU
 AGGUAUUAUCAUUAUU
 GAAAUU
 GUUU
 UUU
 AAUUAAGACAUU
 UUAUU
 UGUUU
 GGUUU
 AAAUU
 GUAGAUGAUUUUAUU
 CAUU
 UUU
 -3'

b 5'- UUGAAGUGUUAAUUGAUAAAACAUCUCUGUUUUUUUUUUUAUCAUUGAAAAC
 UU -3'

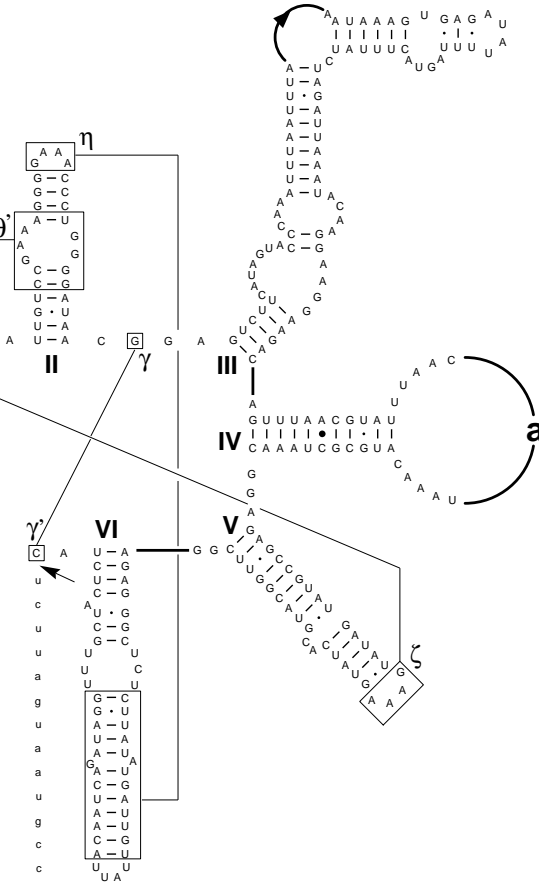

Kluyveromyces lactis:
 Mitochondrion OX1[i1]
 (X57546) (IIA)
 1.Eukaryota 2.eukaryote crown group
 3.Fungi/Metazoa group 4.Fungi
 5.Ascomycota 6.Saccharomycetales
 7.Saccharomycetaceae 8.Kluyveromyces
 October, 2000